

For machines built after 06-2020

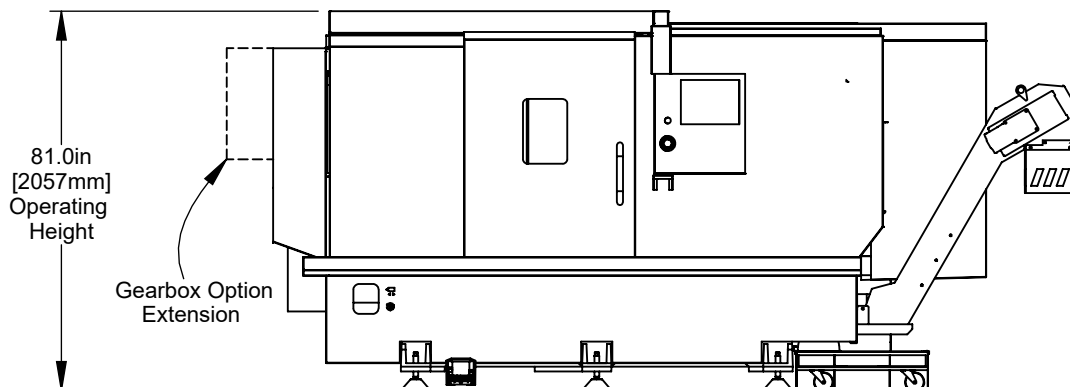

All dimensions based on stackup of sheetmetal, subject to variation of 1/2" (13 mm)

Air & Power

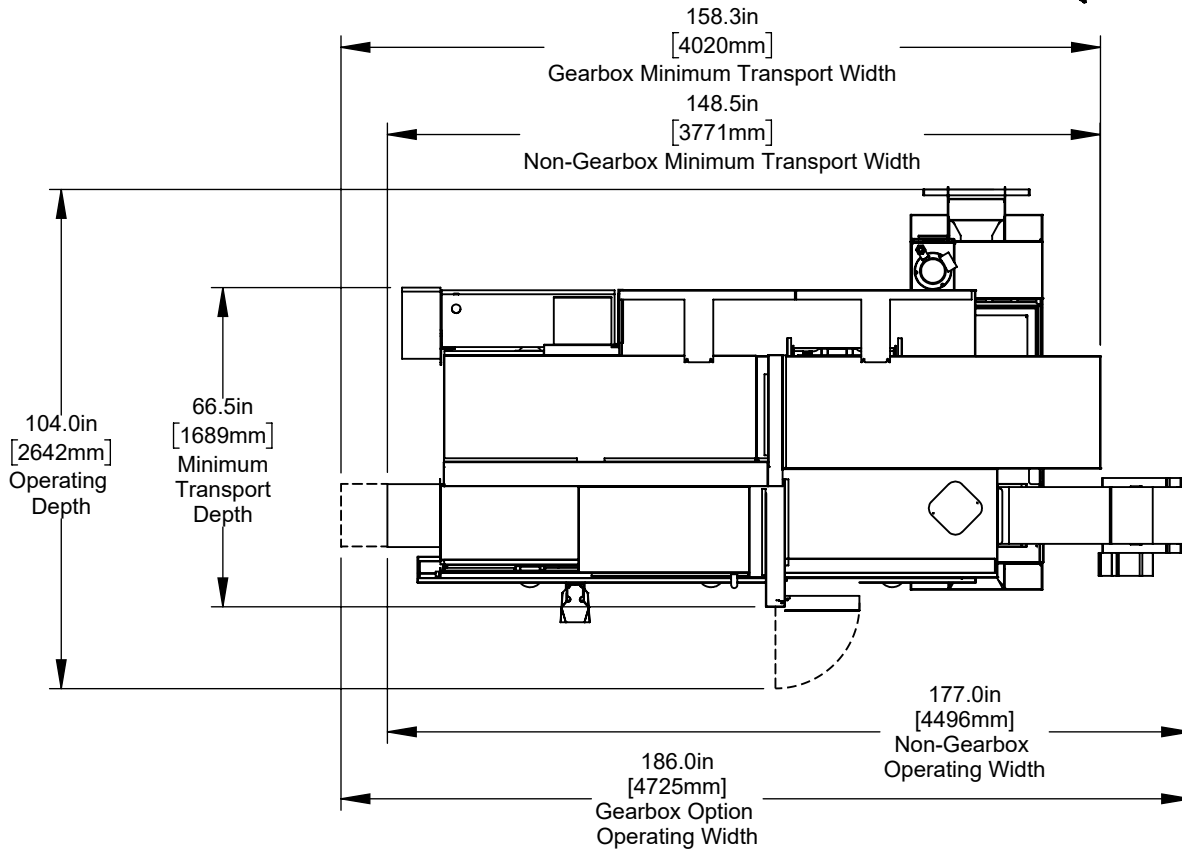
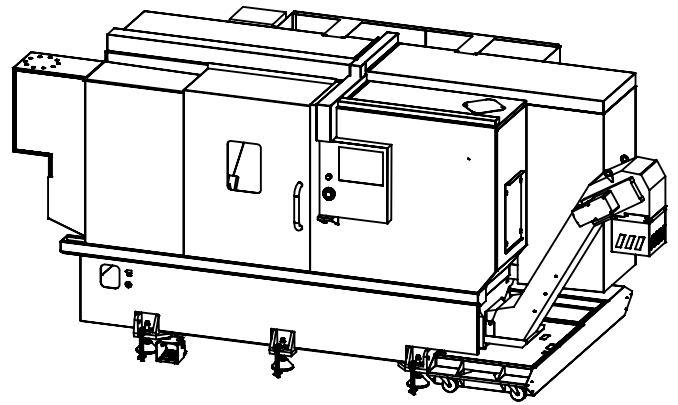
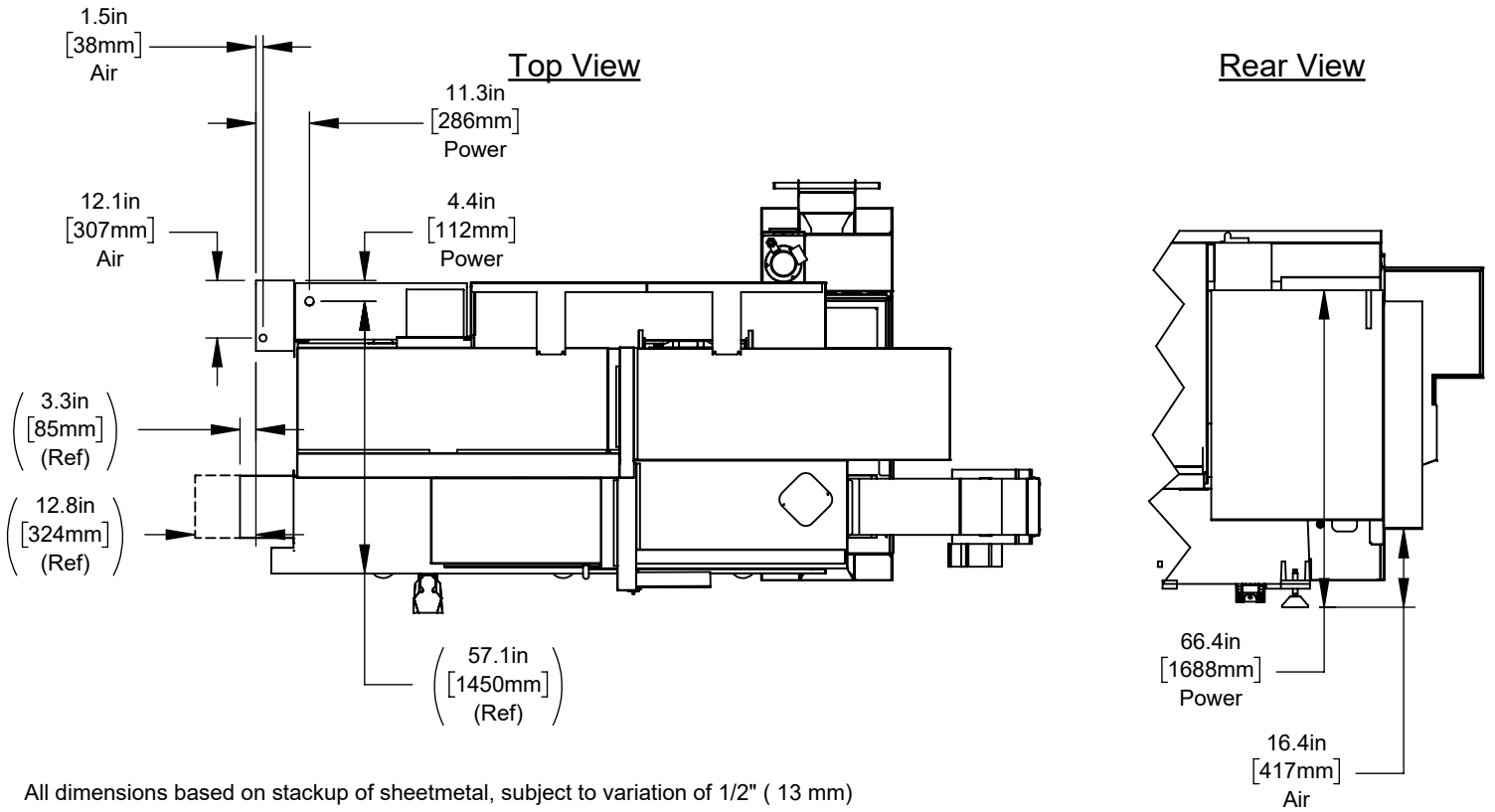

Anchor Pattern

Anchor Hole Detail
 Ø.625in [16mm]
 ∇ 3.5in [89mm]

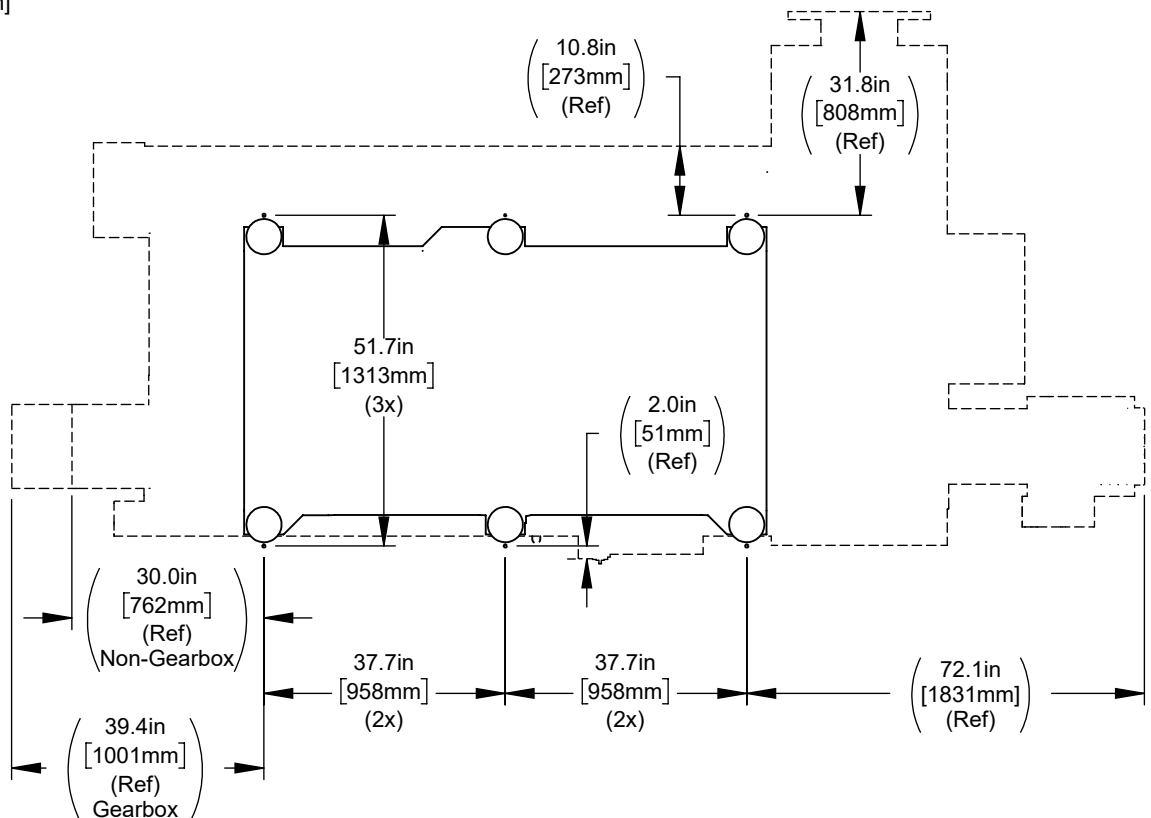

Height Breakdown

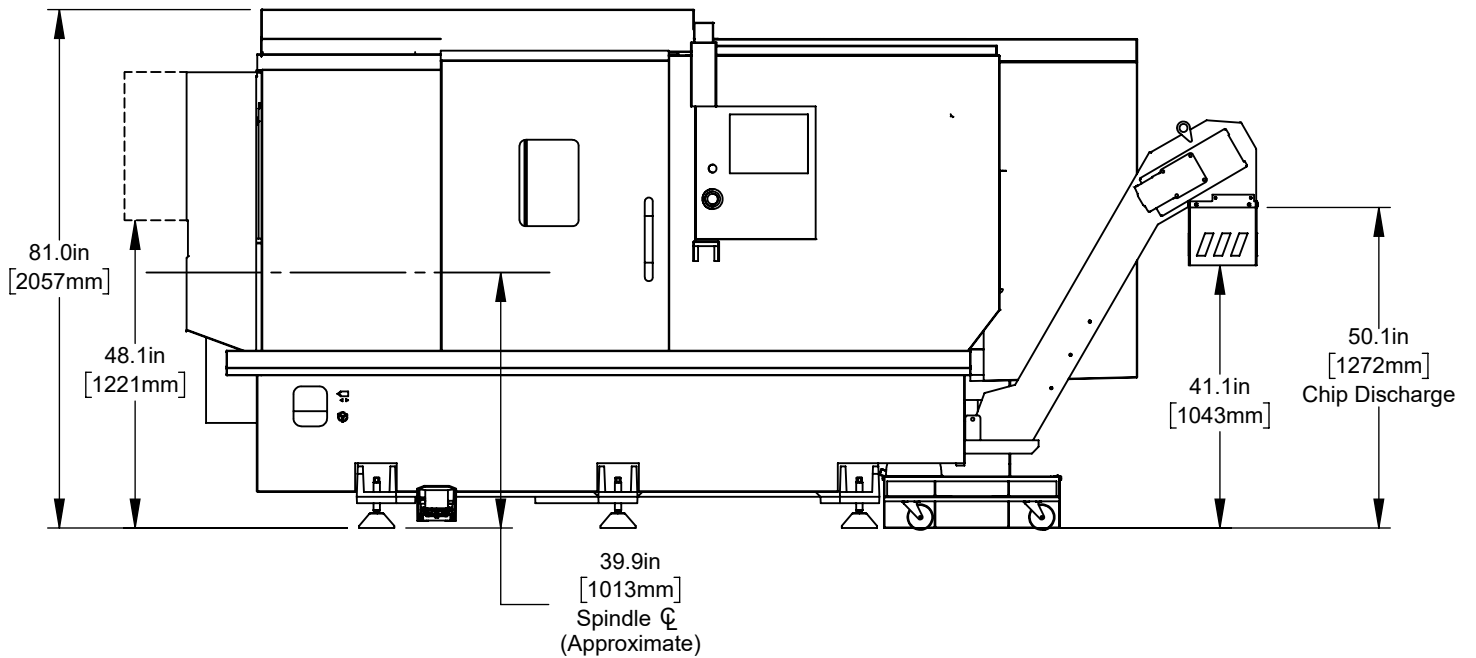

All dimensions based on stackup of sheetmetal, subject to variation of 1/2" (13 mm)

Width Breakdown

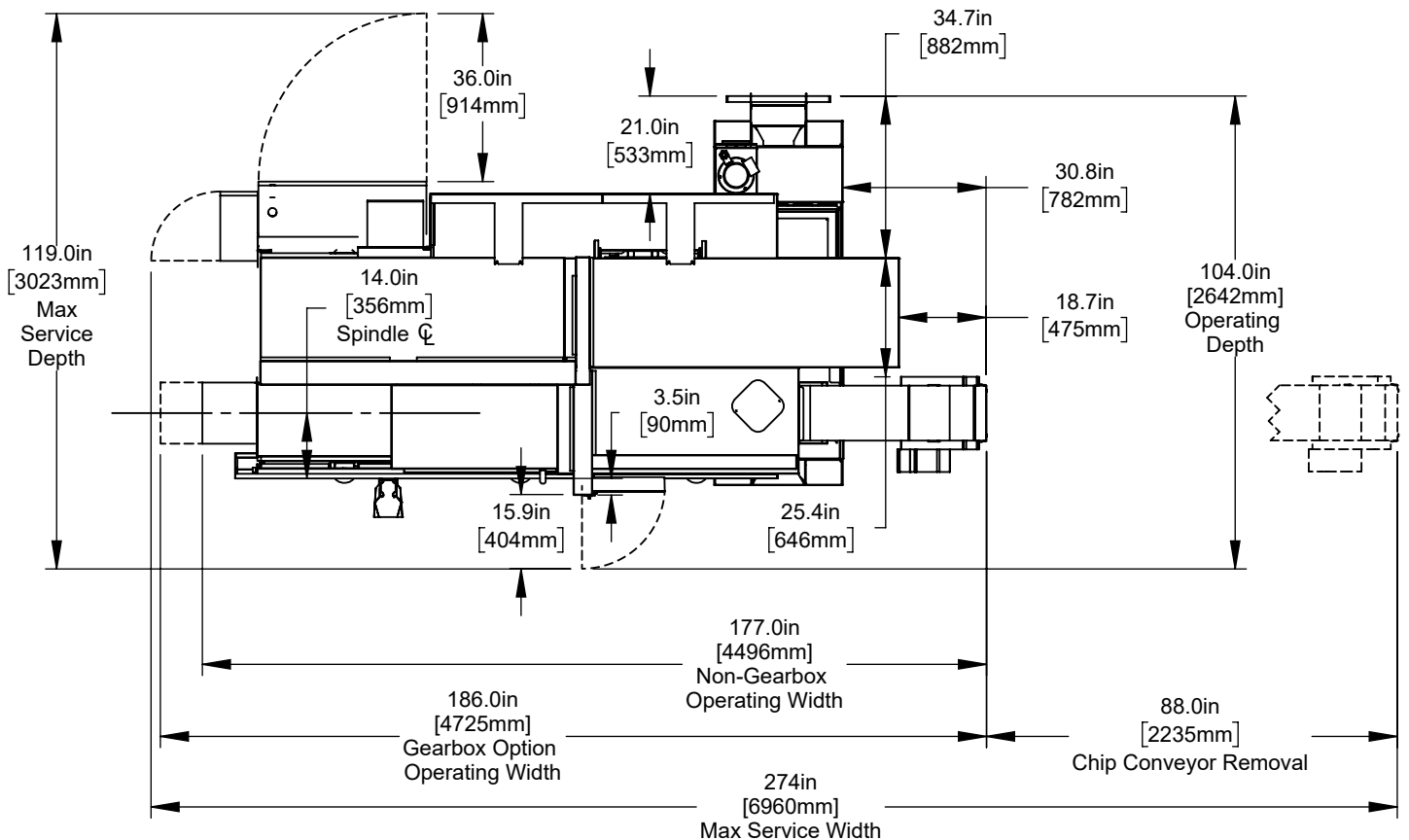

All dimensions based on stackup of sheetmetal, subject to variation of 1/2" (13 mm)

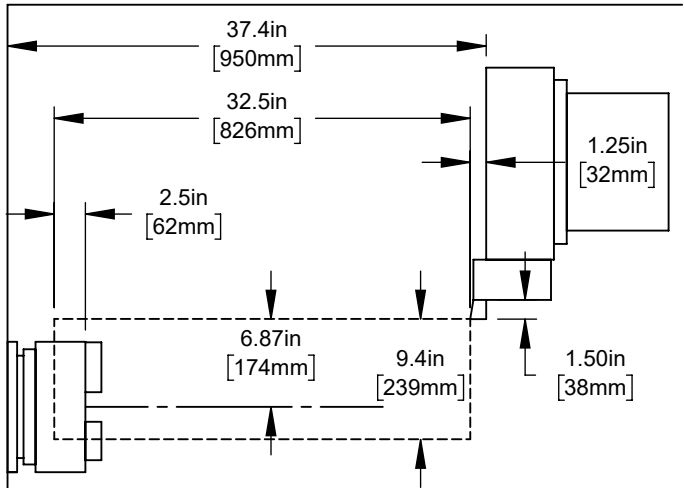

BMT OD

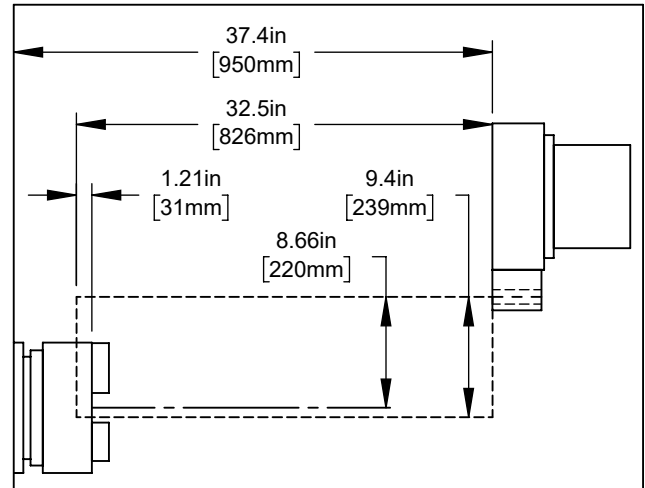

BMT ID / Drill / Bore (*) **

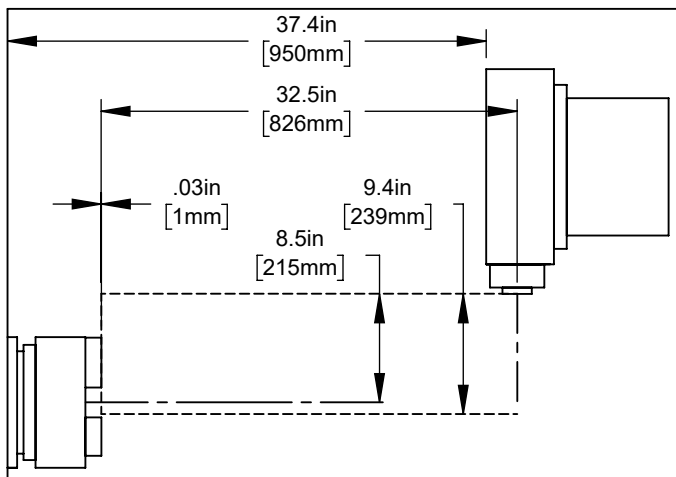

BMT Live Cross Tool *

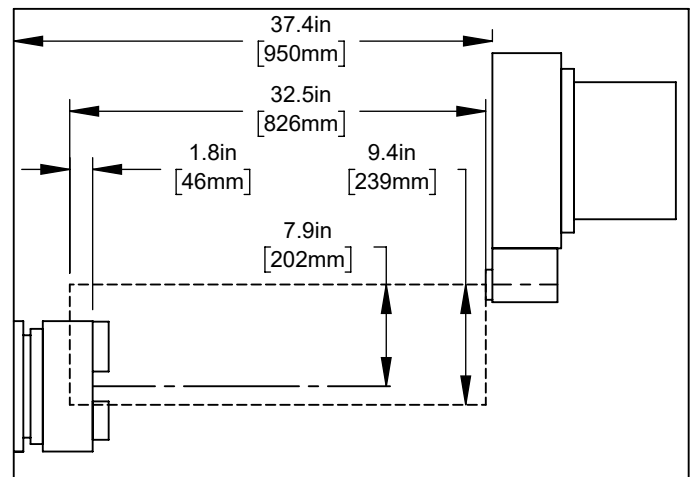

BMT Live Face Tool **

* Shift the work envelope in X by the tool protrusion length (OD) or centerline offset (ID)

** Shift the work envelope in Z by the tool protrusion length

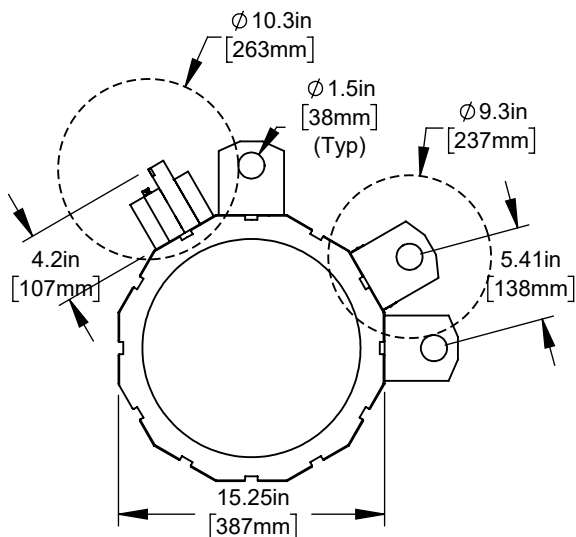

BMT65 Basic Tool Clearance
Maximum Turret Swing \varnothing 35.0in [889mm]

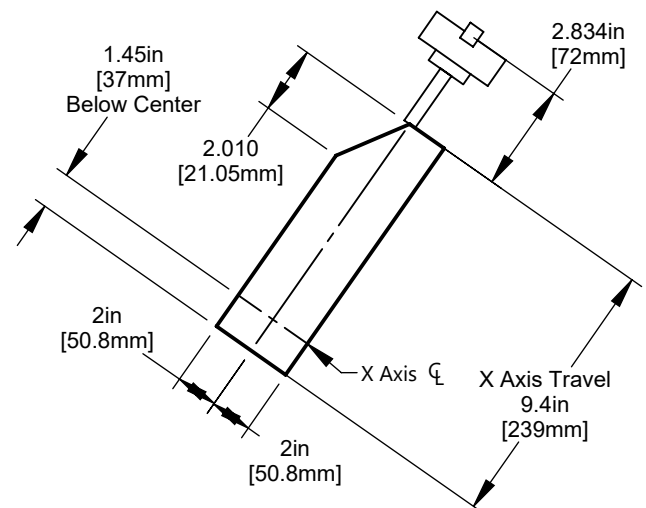

Y Axis Travel Envelope
Same Dimensions Apply To 90° Live Face Tool

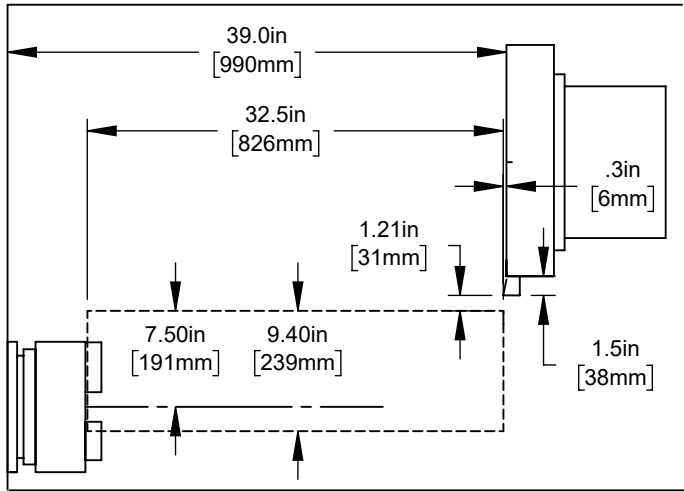

BOT OD

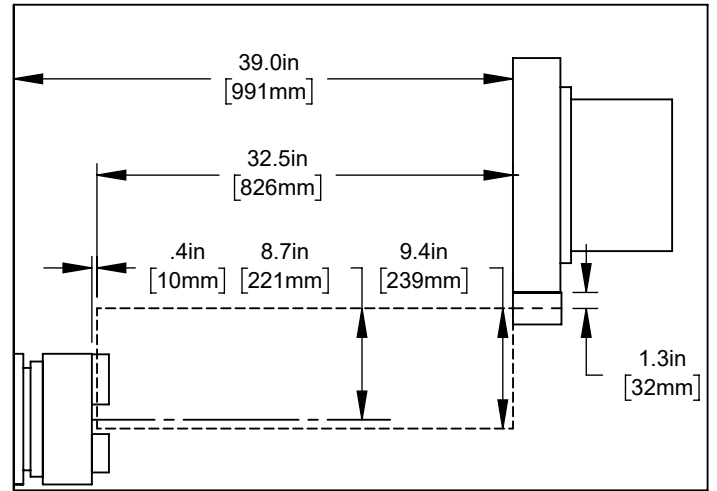

BOT ID / Drill / Bore (*) **

* Shift the work envelope in X by the tool protrusion length (OD) or centerline offset (ID)

** Shift the work envelope in Z by the tool protrusion length

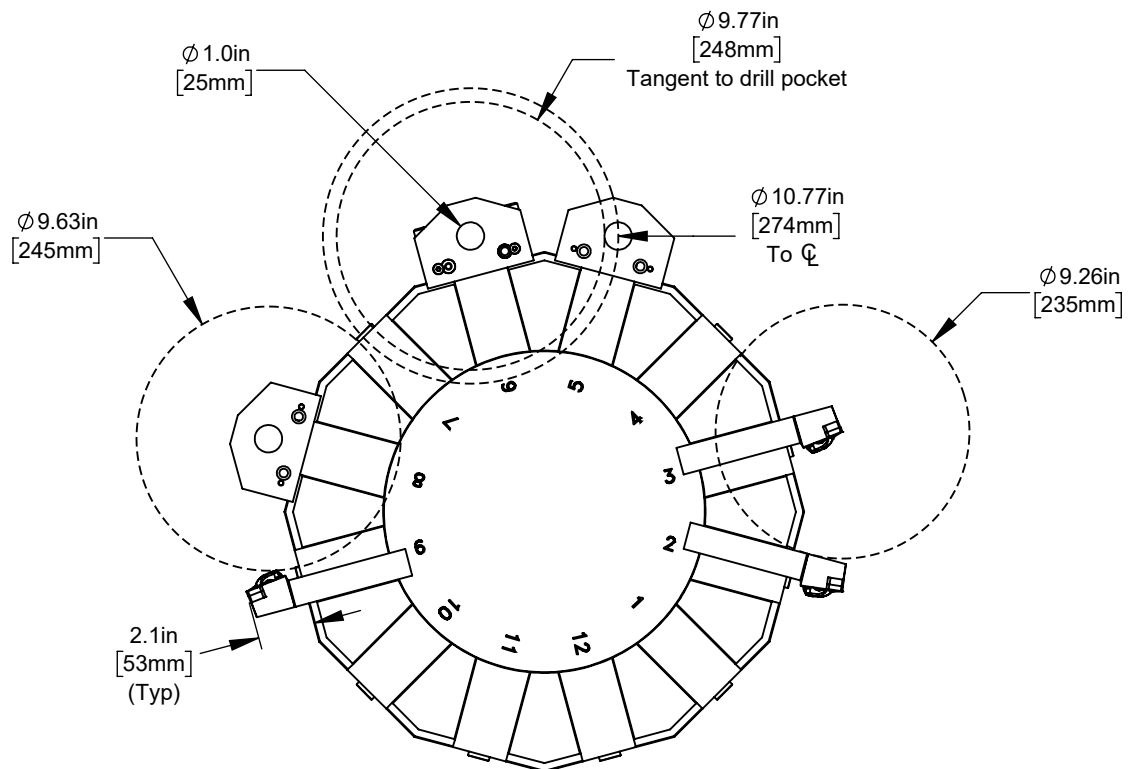

BOT Basic Tool Clearance
Maximum Turret Swing ϕ 35.0in [889mm]

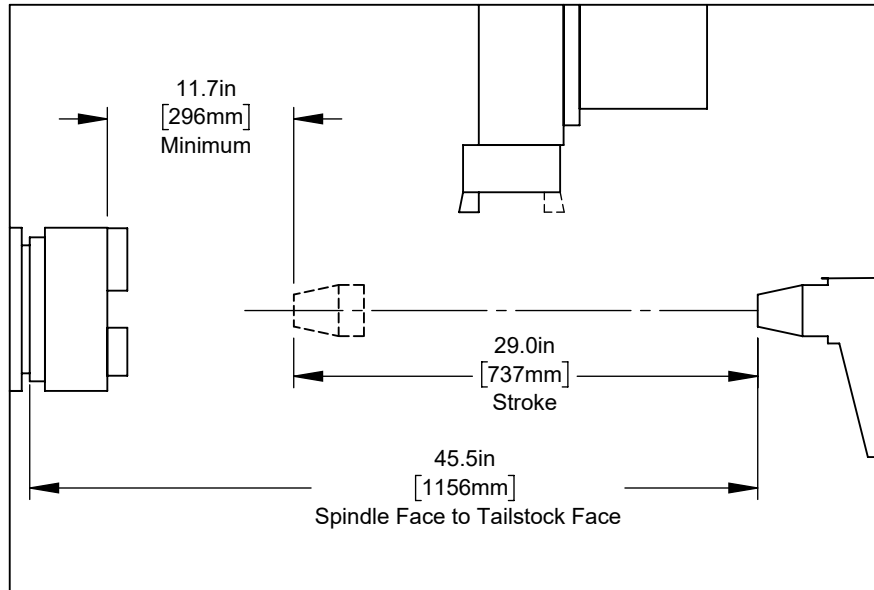

Tailstock Option

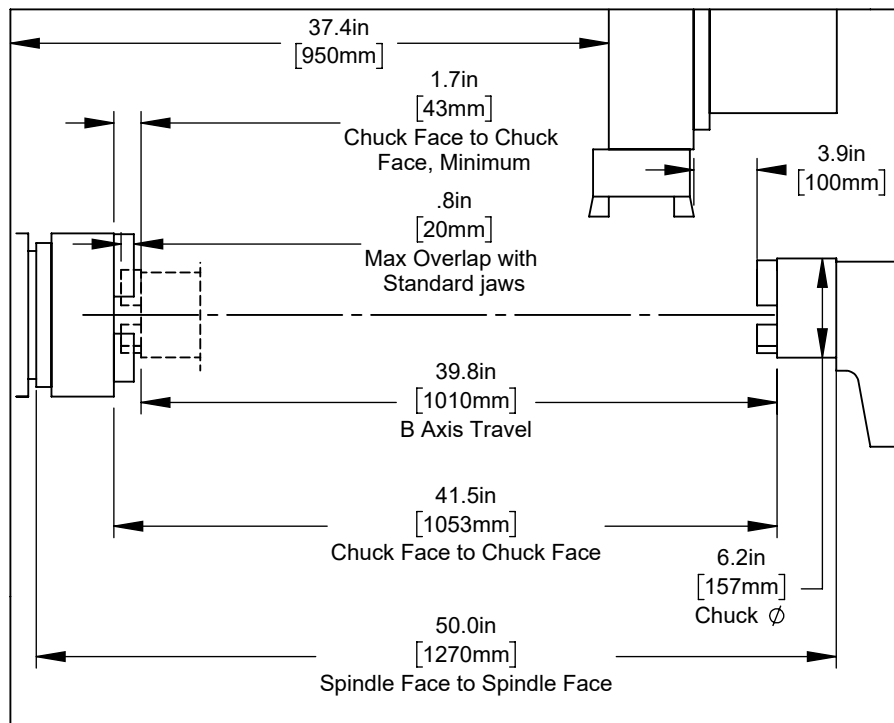

Sub Spindle Option

Bar Feeder Layout

NOTE - Bar Feeder is not compatible with 2 Speed Gearbox option due to interference with extended gearbox shroud.
Barfeeder Diagrams show non-gearbox machine

